

RSX-M1

LM Guide High Temperature Type Model RSX-M1

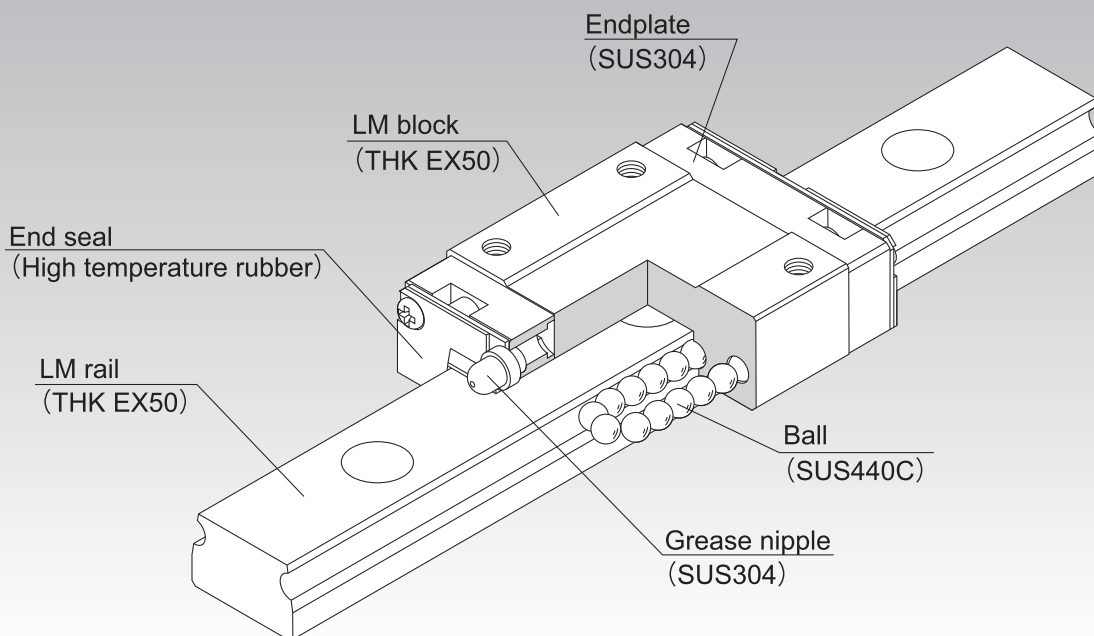

Point of Selection **A1-10**

Point of Design **A1-460**

Options **A1-485**

Model No. **A1-551**

Precautions on Use **A1-557**

Accessories for Lubrication **A24-1**

Mounting Procedure and Maintenance **B1-89**

Equivalent Moment Factor **A1-43**

Rated Loads in All Directions **A1-60**

Equivalent Factor in Each Direction **A1-62**

Radial Clearance **A1-72**

Accuracy Standards **A1-84**

Shoulder Height of the Mounting Base and the Corner Radius **A1-475**

Reference Error Tolerance for the Mounting Surface **A1-477**

Flatness of the Mounting Surface **A1-478**

Dimensions of Each Model with Options Attached **A1-499**

Structure and Features

Balls roll in two rows of raceways precision-ground on an LM rail and an LM block, and endplates incorporated in the LM block allow the balls to circulate.

Despite being compact, the product's ball contact structure is capable of receiving loads in all directions, and it can be used individually in locations with space limitations or where moments are applied.

The high temperature type miniature LM Guide Model RSX-M1 is capable of being used at service temperatures up to 150°C thanks to THK's unique technologies in material, heat treatment, and lubrication.

[Maximum Service Temperature: 150°C]

Use of stainless steel in the endplates and high temperature rubber in the end seals achieves the maximum service temperature of 150°C.

[Dimensional Stability]

Since it is dimensionally stabilized, it demonstrates superb dimensional stability after being heated or cooled (note that it shows linear expansion at high temperature).

[Highly Corrosion Resistant]

Since the LM block, LM rail, and balls use stainless steel, which is highly corrosion resistant, this model is optimal for clean room applications.

[High Temperature Grease]

This model uses high temperature grease that shows little grease-based fluctuation in rolling resistance even if the temperature changes from low to high levels.

Thermal Characteristics of LM Rail and LM Block Materials

- Specific heat capacity: 0.481 J/(g•K)
- Thermal conductivity: 20.67 W/(m•K)
- Average coefficient of linear expansion: $11.8 \times 10^{-6}/^{\circ}\text{C}$

Types and Features

Model RSX-M1

This model is a standard type.

Specification Table⇒ **A1-384**

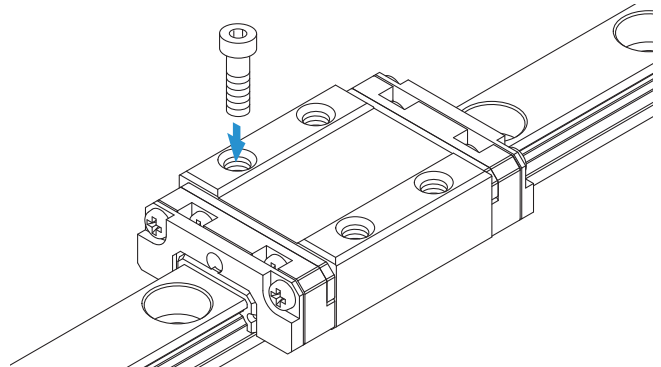

Model RSX-M1N

This type has a longer overall LM block length (L) and a higher load rating than the Model RSX-M1.

Specification Table⇒ **A1-384**

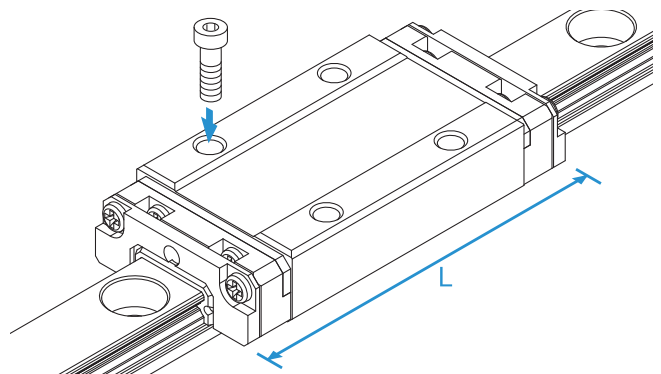

Model RSX-M1W

This type has a longer overall LM block length (L), a greater width, and a larger rated load and permissible moment than the Model RSX-M1.

Specification Table⇒ **A1-386**

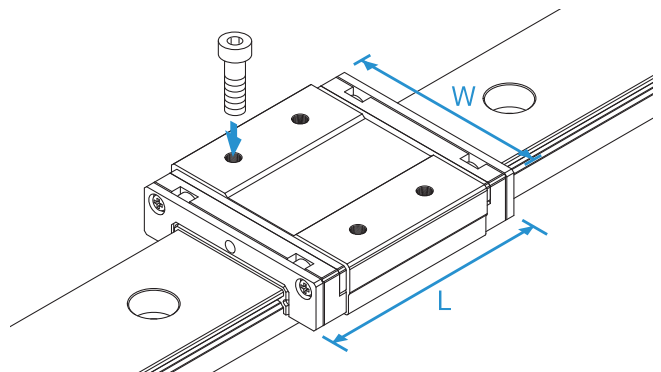

Model RSX-M1WN

This type has a longer overall LM block length (L) and a higher load rating than the Model RSX-M1W.

Specification Table⇒ **A1-386**

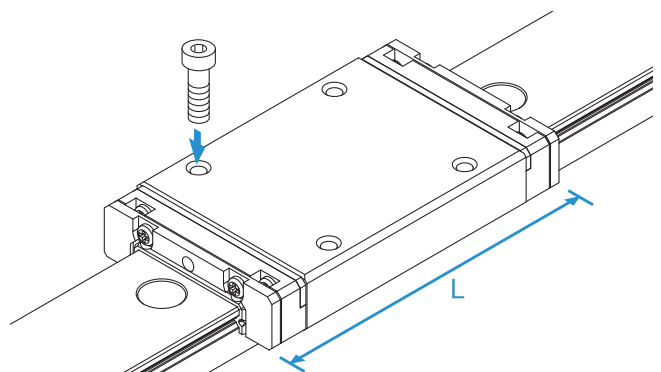

Service Life

When using this product in temperatures higher than 100°C, always multiply the basic dynamic load rating by the temperature coefficient when calculating the rated service life. See **A1-66** for details.

Models RSX-M1 and RSX-M1N

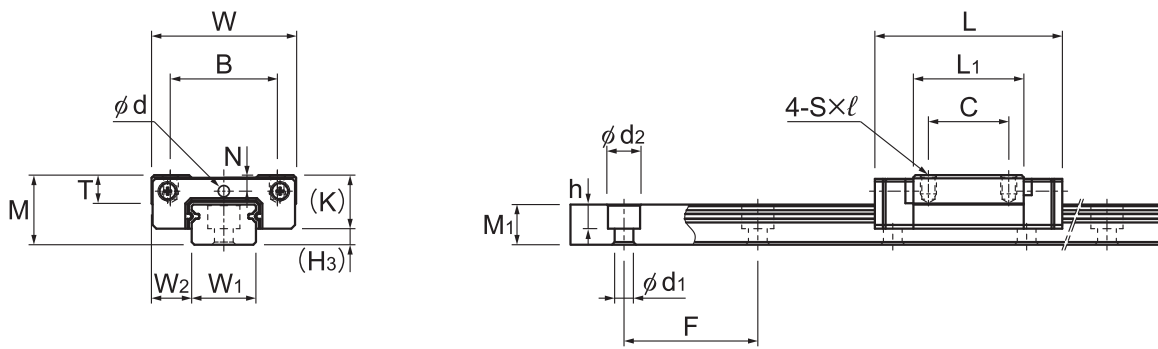

Models RSX9M1, RSX12M1

Model No.	Outer dimensions			LM block dimensions										H ₃
	Height	Width	Length	B	C	S×ℓ	L ₁	T	K	N	E	Greasing hole d	Grease nipple	
	M	W	L											
RSX 9M1 RSX 9M1N	10	20	30.8 40.8	15	10 16	M3×2.8	19.8 29.8	—	7.8	2.4	—	1.6	—	2.2
RSX 12M1 RSX 12M1N	13	27	35 47.7	20	15 20	M3×3.5	20.6 33.3	5.3	10	3	—	2	—	3
RSX 15M1 RSX 15M1N	16	32	42.9 60.7	25	20 25	M3×4	25.7 43.5	5.8	12	3	4	—	PB107	4

Model number coding

2 RSX15 M1 V UU C1 +230L P T - II

2	RSX15	M1	V	UU	C1	+230L	P	T	- II
Model number	Type of LM block	Contamination protection accessory symbol (*2)	LM rail length (in mm)	Symbol for LM rail jointed use	Symbol for No. of rails used on the same plane (*5)				
No. of LM blocks used on the same rail (*1)	Symbol for high temperature type LM Guide	Radial clearance symbol (*3) Normal (No symbol) Light preload (C1)		Accuracy symbol (*4) Normal grade (No symbol)/High accuracy grade (H) Precision grade (P)					

(*1) No symbol for 1 LM block. (*2) See contamination protection accessories on **A1-524**.

(*3) See **A1-72**. (*4) See **A1-84**. (*5) See **A1-13**.

Note) This model number indicates that a single-rail unit constitutes one set (i.e., the required number of sets when 2 rails are used in parallel is 2 at a minimum).

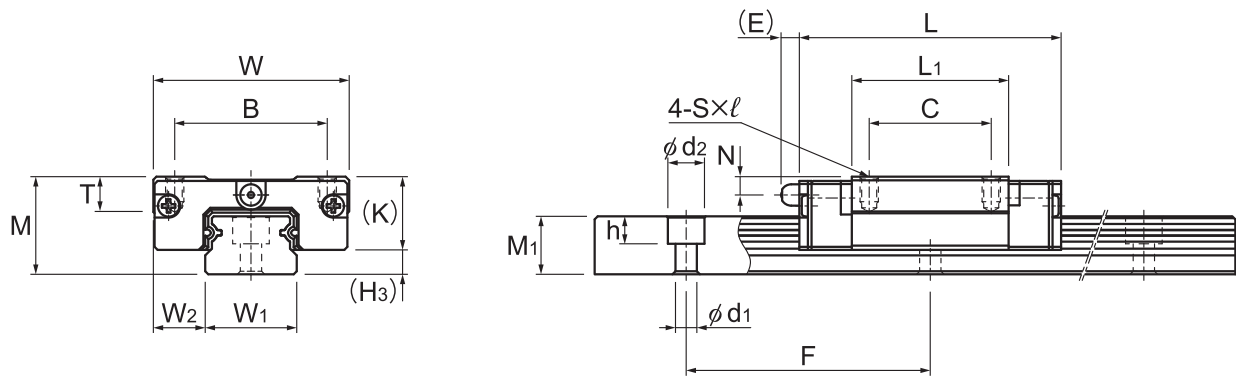

Model RSX15M1

Unit: mm

	LM rail dimensions						Basic load rating		Static permissible moment N·m*					Mass	
	Width		Height	Pitch	Length*	Max	C	C ₀	M _A		M _B		M _C	LM block	LM rail
	W ₁	W ₂	M ₁	F					d ₁ × d ₂ × h	1 block	2 blocks	1 block	2 blocks		
	9 ⁰ _{-0.02}	5.5	5.5	20	3.5 × 6 × 3.3	1240	2.22 2.94	3.06 4.59	9.87 21.1	57.9 111	11.4 24.4	66.9 128	14.1 21.1	0.018 0.024	0.32
	12 ⁰ _{-0.02}	7.5	7.5	25	3.5 × 6 × 4.5	2000	3.36 4.72	4.21 6.83	14.2 34.8	92.5 195	14.2 34.8	92.5 195	27.6 44.7	0.037 0.047	0.65
	15 ⁰ _{-0.02}	8.5	9.5	40	3.5 × 6 × 4.5	2000	5.59 8.27	6.78 11.8	29 82.1	186 432	29 82.1	186 432	48.1 84.3	0.069 0.089	0.96

Note1) The maximum length under "Length*" indicates the standard maximum length of an LM rail. (See **A1-388**.)

Static permissible moment* 1 block: the static permissible moment with one LM block

2 blocks: static permissible moment when two LM blocks are in close contact with each other

Total block length L The total block length L shown in the table is the length with the dust-proof parts (code: UU).

Please be aware that balls will fall out if the LM block is removed from the LM rail.

Note2) The basic load rating in the dimension table is for a load in the radial direction. Use Table7 on **A1-60** to calculate the load rating for loads in the reverse radial direction or lateral direction.

Models RSX-M1W and RSX-M1WN

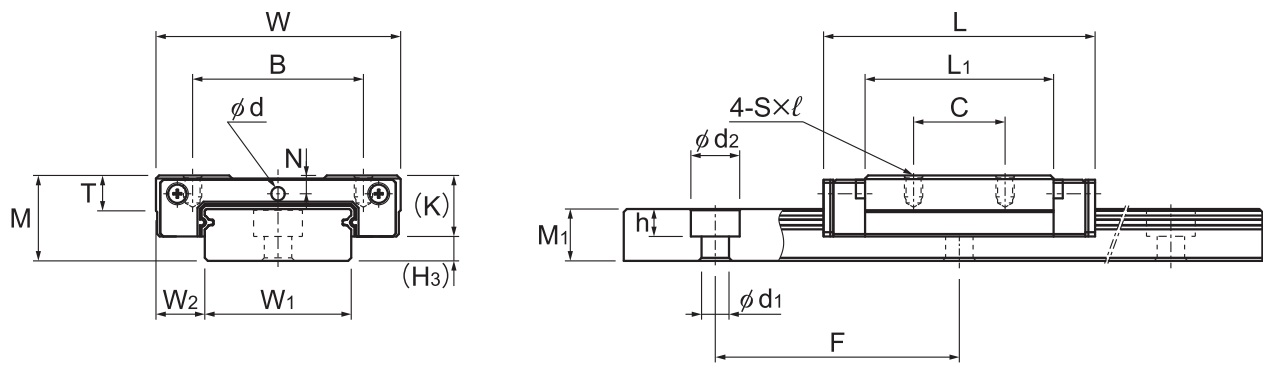

Models RSX9M1W, RSX12M1W

Model No.	Outer dimensions			LM block dimensions										H ₃
	Height	Width	Length	B	C	S×l	L ₁	T	K	N	E	Greasing hole d	Grease nipple	
	M	W	L	B	C	S×l	L ₁	T	K	N	E	d		H ₃
RSX 9M1W RSX 9M1WN	12	30	39 50.7	21 23	12 24	M3×2.8	27 38.7	—	8.3	2.3	—	1.6	—	3.7
RSX 12M1W RSX 12M1WN	14	40	44.5 59.5	28	15 28	M3×3.5	30.9 45.9	4.5	10	3	—	2	—	4
RSX 15M1W RSX 15M1WN	16	60	55.5 74.5	45	20 35	M4×4.5	38.9 57.9	5.6	12	3	4	—	PB107	4

Model number coding

2	RSX12	M1	WN	UU	C1	+310L	P	T
No. of LM blocks used on the same rail (*1)	Model number	Type of LM block	Symbol for high temperature type LM Guide	Contamination protection accessory symbol (*2)	Radial clearance symbol (*3)	LM rail length (in mm)	Accuracy symbol (*4)	Symbol for LM rail jointed use
					Normal (No symbol) Light preload (C1)		Normal grade (No symbol)/High accuracy grade (H) Precision grade (P)	

(*1) No symbol for 1 LM block.

(*2) See contamination protection accessories on **A1-524**. (*3) See **A1-72**. (*4) See **A1-84**.

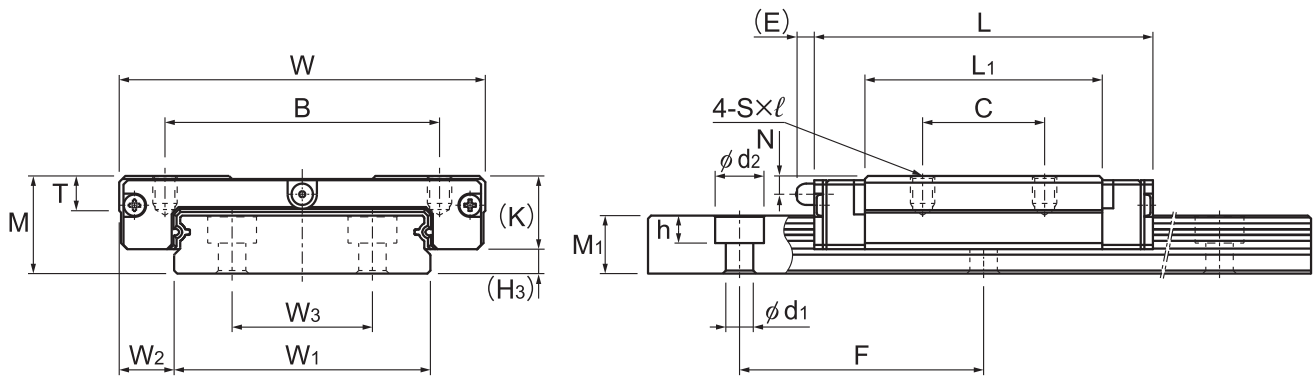

Model RSX15M1W

Unit: mm

	LM rail dimensions							Basic load rating		Static permissible moment N·m*					Mass	
	Width		Height	Pitch	Length*	C	C ₀	M _A		M _B		M _C	LM block	LM rail		
	W ₁	W ₂						1 block	2 blocks	1 block	2 blocks	1 block			kg	kg/m
	18 ⁰ _{-0.02}	6	—	7.5	30	3.5×6×4.5	1430	2.8 3.48	4.28 5.81	18.5 33.2	99.3 172	21.4 38.3	115 199	40.5 54.9	0.035 0.048	1.01
	24 ⁰ _{-0.02}	8	—	8.5	40	4.5×8×4.5	2000	4.46 5.93	6.31 9.46	30 64.7	171 332	30 64.7	171 332	79.2 119	0.075 0.091	1.52
	42 ⁰ _{-0.02}	9	23	9.5	40	4.5×8×4.5	2000	7.43 9.87	10.1 15.2	61.4 133	343 670	61.4 133	343 670	211 316	0.17 0.195	2.87

Note1) The maximum length under "Length*" indicates the standard maximum length of an LM rail. (See **A1-388**.)

Static permissible moment* 1 block: the static permissible moment with one LM block

2 blocks: static permissible moment when two LM blocks are in close contact with each other

Total block length L

The total block length L shown in the table is the length with the dust-proof parts (code: UU).

Please be aware that balls will fall out if the LM block is removed from the LM rail.

Note2) The basic load rating in the dimension table is for a load in the radial direction. Use Table7 on **A1-60** to calculate the load rating for loads in the reverse radial direction or lateral direction.

Standard Length and Maximum Length of the LM Rail

Table1 shows the standard and maximum lengths of the RSX-M1 model rail.

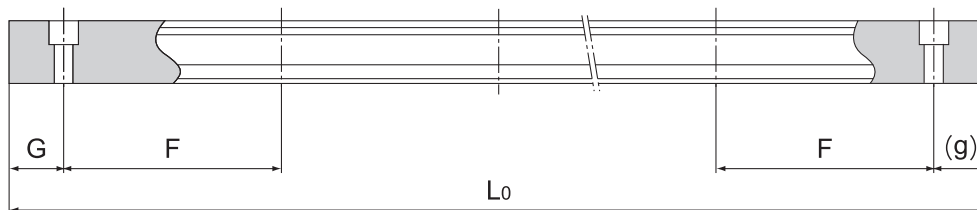

Table1 Standard Length and Maximum Length of the LM Rail for Model RSX-M1

Unit: mm

Model No.	RSX 9M1	RSX 9M1W	RSX 12M1	RSX 12M1W	RSX 15M1	RSX 15M1W
LM rail standard length (L_0)	55	50	70	70	70	110
	75	80	95	110	110	150
	95	110	120	150	150	190
	115	140	145	190	190	230
	135	170	170	230	230	270
	155	200	195	270	270	310
	175	260	220	310	310	430
	195	290	245	390	350	550
	275	320	270	470	390	670
	375		320	550	430	790
			370		470	
		470		550		
		570		670		
				870		
Standard pitch F	20	30	25	40	40	40
G,g	7.5	10	10	15	15	15
Max length	1240	1430	2000	2000	2000	2000

Note) The maximum length varies with accuracy grades. Contact THK for details.

